



**GTR REGULAR
ROBUSTNESS
GAS-TIGHT SUIT
CHEMPROTEX™ X**



INSTRUCTIONS FOR USE



EN 943-2:2019
TYPE 1a-ET

Contents

General Information.....	1
Suit Features	1
Limitations & Warnings 	2
Physical Properties of Chemprotex™ X Suit Material.....	3
Fitting Gloves Into The Respirer Locking Cuff.....	4
Assembly Of Boot Into Detachable Boot System	5
Removing Boot From Detachable Boot System	6
Recommended Donning Procedure.....	7
Recommended Doffing Procedure.....	8
Replacing Exhalation Valve Diaphragm.....	9
Removing Exhalation Valve Assembly	10
Replacing Exhalation Valve Assembly.....	10
Decontamination	11
Cleaning Accessories.....	11
Storage.....	11
Conducting An Internal Pressure Test	12
Chemical Permeation Testing At Respirer	14
Permeation Performance	14
Sizing.....	15
Product labelling	16

General Information

You have purchased a Respirix regular robustness chemical protective gas-tight suit manufactured from **Chemprotex™ X**, a high-performance chemical protective clothing material developed by for protection against gaseous, liquid and solid chemicals. The suit is for use within certain contaminated environments only and you should carefully read and follow these operating instructions closely.

All Respirix regular robustness gas-tight suits are UKCA and CE marked to indicate compliance with European Regulation 2016/425 on personal protective equipment (PPE) and Regulation 2016/425 on personal protective equipment as brought into UK law and amended. The suit has been tested and marked in accordance with EN943-2:2019, this standard specifies performance requirements both for materials of construction and for the suit as a whole.

Worn in conjunction with suitable gloves and safety boots, Respirix regular robustness gas-tight suits manufactured from **Chemprotex™ X** meet the performance requirements of a **TYPE 1a-ET** regular robustness “gas-tight” chemical protective suit for emergency teams.

Respirix regular robustness gas-tight suits must be worn in conjunction with self-contained open-circuit compressed air breathing apparatus conforming to EN 137. All declarations of conformity: <http://www.respirix.co.uk/doc>

Suit Features

The regular robustness gas-tight suit is a one-piece coverall designed to enclose the wearer's whole body and self-contained breathing apparatus (SCBA).

A large semi-rigid visor is bonded to the suit produced from materials designed to be resistant to permeation against the chemicals listed in EN943-2:2019.

Two exhalation valves are fitted which automatically release excess pressure that builds up inside the suit. This ensures that the pressure within the suit does not exceed 400 Pa, as required by EN 943-1:2015+A1:2019.

A 120cm (48”) long gas-tight zipper is fitted to the right hand side of the suit which enables easy donning or doffing. The zipper is shrouded by two outer flaps which must be fastened together by means of a Velcro strip when the suit is in use.

The legs of the suit are fitted with integral booties that are designed to be worn inside a suitable pair of safety boots. Outer splash guards that prevent liquid ingress into the wearer's safety boots are also attached to the legs. Alternatively, highly chemically resistant safety boots conforming to EN 20345 (Type FPA) with steel toe cap and mid-soles can be either permanently bonded to the suit or fitted by means of the Respirix detachable boot system (see page 5).

The regular robustness gas-tight suit is supplied with a dual glove system that consists of a laminated inner glove with excellent resistance to permeation by chemicals (Kemblok™) bonded to an outer neoprene glove that provides a degree of protection against mechanical hazards. The outer neoprene glove also offers a limited amount of resistance to permeation by chemicals. The gloves are fitted to the suit by means of the Respirix locking cuff system.

The waist of the suit is supported by means of an internal belt.

As an option the suit can be fitted with an attachment that enables supplementary air to be passed to the ancillary airline connection of the wearer's self-contained breathing apparatus, this can be via either,

- a). Low pressure pass-thru
- b). High pressure pass-thru

Low Pressure Pass -Thru

This is a 360° swivel unit that will withstand the working pressure of a two-stage breathing apparatus. On the inside of the suit is a length of airline hose with a coupling that connects to the ancillary airline connection on the wearer's self-contained breathing apparatus. The maximum working pressure of this unit is 10 bar.

High Pressure Pass -Thru

As low pressure pass-thru but will withstand the working pressure of a single-stage breathing apparatus set. The maximum working pressure of this unit is 10 bar.

Accessory Attachment Points

The suit can be fitted with various accessory attachment points intended to carry life lines, personal lines, torches, distress signal units (DSU) etc.

Limitations & Warnings

Respirex regular robustness gas-tight suits should only be worn by persons who have been fully trained and are familiar with suit equipment. It is essential to ensure that the suit you are wearing is made from a material that will give you adequate protection against the chemical hazard you are about to encounter.

Regular robustness gas-tight suits manufactured from **Chemprotex™ X** are designed to be worn until hygienic cleaning becomes necessary or limited use chemical contamination has occurred and disposal is required.

If, after use, you consider that the suit has not been damaged and that the chemical exposure to the fabric surface is very limited, it would need to be decontaminated in the proper fashion before being re-packed for use. The decision to re-use the suit is a subjective one. A certain amount of professional assistance can be offered by Respirex but the end-user shall be the sole judge on whether or not the suit can be adequately cleaned or decontaminated for re-use.

Respirex can offer advice on the breakthrough time for the chemical substance the suit has come into contact with to assist the end-user in deciding whether to re-use the garment.

If the suit becomes heavily contaminated or mechanically damaged in any way it

MUST NOT be reused and **MUST** be disposed of.

Chemprotex™ X material is made of polymers which do not contain halogens in their structural formula. Depending on the chemical nature and the amount of contamination on the garments, garments made from Chemprotex™ X could be either incinerated after use, without any harm to the environment, or buried in a responsible way. On incineration of the garment itself, traces of halogens in combustion gases and ash are at the level of ordinary halogen contamination in any non-halogen containing industrial product. Restrictions to the disposal of used regular robustness gas-tight suits manufactured from Chemprotex™ X depends on the contaminant.

Chemprotex™ X material is designed specifically for regular robustness garments. Excessive flexing or folding can lead to weaknesses in the structure of the material which may have an adverse effect on the chemical resistance offered by the suit. Nevertheless extensive operational use of garments manufactured from **Chemprotex™ X** has demonstrated its durability beyond that of a single-use fabric.

Caution: Chemprotex™ X is a non-breathable material and the wearer's body temperature will rise whilst wearing the suit, particularly during periods of intense physical activity. Wherever possible operational procedures should be planned to minimise the risk of heat stress occurring. The wearer should leave the work area and disrobe the suit before becoming distressed.

Chemprotex™ X meets the resistance to ignition requirements of EN 943-1:2015+A1:2019 but is not flame resistant. Suits manufactured from **Chemprotex™ X** should not be worn in potentially flammable or explosive environments. **Chemprotex™ X is flammable material keep away from fire.** There is no anti-static treatment applied to **Chemprotex™ X**

The usable temperature range of **Chemprotex™ X** material is -70°C to 90°C. Note : This usable temperature range is based on the evaluation of the physical properties of the material only. Users should note that resistance to permeation by chemicals varies with temperature.

Continuous contact with certain chemicals can adversely affect the field of vision and protection offered by the visor. If any discolouration of the visor is apparent the suit **MUST NOT** be re-used.

Always use compatible PPE, e.g. gloves and safety boots advised by Respirex.

For any enquiries please contact the Respirex customer services department on Tel : +44 (0)1737 778 600,

Fax : +44 (0)1737 779 441 or Email : info@respirex.co.uk.

Physical Properties of Chemprotex™ X Suit Material

The samples submitted were tested in accordance with Table 1 of EN 943-2:2019.

Property	Test Method	Property value of Chemprotex™ X	Performance class of Chemprotex™ X	Minimum performance class required for EN 943-2:2019
Basis Weight	ISO 536:1995	360 g/m ²	N/A	N/A
Thickness	ISO 534:1998	500 µm	N/A	N/A
Abrasion resistance	EN ISO 12947-2 (inc. pressure drop)	> 2000 cycles	6 (out of 6)	4
Flex cracking resistance	ISO 7854 Method B (inc. pressure drop)	> 1250 cycles	2 (out of 6)	1
Trapezoidal tear resistance	EN ISO 9073-4	> 100 N	6 (out of 6)	3
Puncture resistance	EN 863	> 50 N	3 (out of 6)	2*
Tensile Strength	EN ISO 13934-1	> 250 N	4 (out of 6)	4
Resistance to flame	EN 13274-4:2001 Meth 3 modified (inc. pressure drop)	No part ignited or continued to burn on removal from the flame	2 (out of 3)	1
Seam strength	ISO 5082:1982 Annex A2†	> 500 N	6 (out of 6)	5

Key:

N/A = Not applicable

* The suit may not be suitable for use where there is a high risk of puncture.

Fitting Gloves Into The Respirex Locking Cuff

1. Turn the sleeves of the suit inside out.
2. Carefully slide the tapered cone inside the Kembrok™/neoprene gloves so that they stretch over the cone (see Figs 1 & 2).



Fig. 1



Fig. 2

3. Push the gloves and cone into the cuff body with the little finger of the gloves at 90° to the seam at the rear of the sleeve (see Fig 3).
4. Make sure that the gloves and cone are pushed into the cuff body with equal pressure all around its circumference (see Fig 4).



Fig. 3



Fig. 4

5. Locate the locking ring over the gauntlet of the gloves and screw into the cuff body (see Fig 5). If necessary the gauntlet section of the gloves can be cut down if they are causing interference with the locking ring.
6. Turn the sleeve the correct way out by carefully pulling on the glove (see Fig 6).

Check that there are no creases in the outer neoprene glove around the cuff seal. If there are any creases or the glove is pinched in any way it should be removed and re-fitted. If the cuff and gloves have been assembled as described there should now be a gas tight wrist seal.



Fig. 5



Fig. 6

Assembly Of Boot Into Detachable Boot System

1. Fit the rubber 'O' ring (D00693) into the groove on the boot sealing collar. Locate the 'O' ring at the bottom of the groove, Figs.7 & 8.



Fig. 7

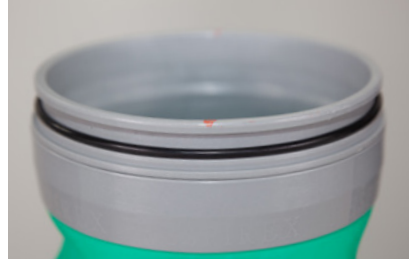

Fig. 8

2. If there is an 'O' ring already fitted, check that it is not damaged. If in doubt fit a new 'O' ring (D00693) to the boot sealing collar.
3. With the leg of the suit turned inside out, locate the boot through the leg sealing collar so that the 'O' ring can be seen in the groove. Ensure that the boot is facing in the correct direction, Fig.9.
4. Locate the retaining collar (B01603) around the top groove of the leg sealing collar and snap into position, Fig.10.



Fig. 9



Fig. 10

5. When snapped into position the retaining collar should appear as shown in Fig.11.
6. Pull the boot sealing collar up so that the retaining collar is trapped in position as shown in Fig.12.

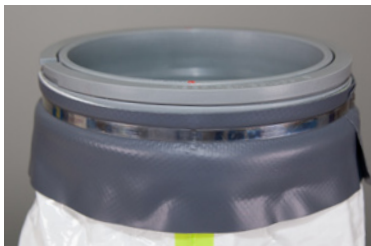

Fig. 11



Fig. 12

7. Turn the PVC protective strip up over the stainless steel band as shown in Fig.13.
8. Pull the leg of the garment through. The final assembly of the boot into the detachable boot system should appear as shown in Fig.14.



Fig. 13



Fig. 14

Parts required:

- Rubber 'O' ring - Part number D00693
- Retaining collar - Part number B01603

Removing Boot From Detachable Boot System

1. Turn the leg of the suit inside out. Fold down the PVC protective strip then pull the leg sealing collar down so that a gap appears under the retaining collar as shown in Fig. 15.
2. Using a pair of external circlip pliers remove the retaining collar as shown in Fig. 16.
3. Push the boot sealing collar through the leg sealing collar and remove the boot from the suit leg, Fig. 17.

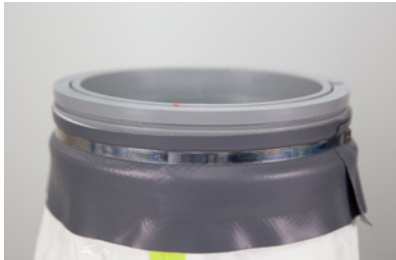

Fig. 15



Fig. 16



Fig. 17

Recommended Donning Procedure

Donning the regular robustness gas-tight suit is a very simple matter, although it will be necessary for a dresser to assist the wearer in the donning procedure.

1. Unzip the suit by pulling approximately 61cm (24") at a time, keeping the zipper straight with one hand as you pull the slider with the other. Repeat this exercise for the whole length of the zip. **FAILURE TO FOLLOW THIS PROCEDURE MAY RESULT IN THE ZIP BECOMING JAMMED.**
2. Fold up the outer splash guards approximately 20-23cms (8"-9") and fold down the suit to expose the top of the integral booties. The wearer should step into the integral booties and then into a pair of safety boots. Fold the outer splash guards down over the exterior of the safety boots and with the aid of the dresser lift the suit to the waist, making sure the crotch is positioned comfortably. The suit waist belt should be fastened firmly ensuring that it is not twisted (see Figs 18 & 19). Note: Suits fitted with integral safety boots are not supplied with outer splash guards.



Fig. 18



Fig. 19

3. With the assistance of the dresser the wearer should now don a self-contained breathing apparatus set (SCBA) in the usual manner, but without starting up. Leave the face mask of the SCBA hanging on its strap around the wearer's neck. The dresser should lift the pod at the rear of the suit up and over the SCBA cylinder. The wearer can now carry out all SCBA necessary pre-checks.
4. Next, the SCBA cylinder should be switched on in accordance with the manufacturer's instructions and the face mask donned by the wearer. The dresser can assist the wearer to adjust the head straps of the face mask until comfortable. If required a fireman's safety helmet can now also be donned by the wearer.

5. The wearer's arms should be folded across the chest whilst the dresser lifts the suit up and over the wearer's shoulders and head and fastens the zip carefully following the procedure outlined in stage 1. The wearer's arms can now be slid down the sleeves and into the gloves (see Figs 20 & 21).
6. Finally the outer zip flaps should be sealed together using the Velcro fastening provided (Fig 22).



Fig. 20



Fig. 21



Fig. 22

Recommended Doffing Procedure

Firstly the suit must be decontaminated sufficiently to safely remove the wearer from the garment (**see Decontamination**). It will be necessary for the dresser to aid the wearer to remove the suit (it is **ESSENTIAL** that the dresser wears suitable protective clothing).

1. The wearer's arms should be removed from the sleeves and folded across the chest.
2. The dresser should unzip the suit carefully (following the procedure outlined in the dressing instructions).
3. Fold the suit over the wearer's head and off the SCBA down to the waist. The outer surface of the suit should be kept away from the wearer at all time.
4. Shut down the SCBA cylinder according to the manufacturer's instructions having removed the wearer's face mask. With the assistance of the dresser the BA can now be removed in the usual way.
5. Unfasten the suit waist belt.
6. Fold the suit down to the top of the integral socks (or safety boots) so that the wearer can step out of the suit.

Replacing Exhalation Valve Diaphragm

1. Using a torque driver with a 'T8' Torx bit, loosen and remove the screw from the centre of the exhalation valve, then remove the cap.
2. Carefully slide the diaphragm up the central spigot and remove from the exhalation valve body.
3. Check that there is no dust, debris or contamination of any kind in the exhalation valve body.
4. Carefully slide a new diaphragm down the central spigot until it rests evenly on the valve body. Ensure the diaphragm is correctly orientated with the ridged side uppermost (see Fig 24).
5. Replace the exhalation valve cap and ensure the two locating channels engage with the locating keys on either side of the valve body. **Note:** When correctly located, the valve cap will not rotate independently on the valve body.
6. Replace the centre screw, turn by hand two times to engage the thread with the valve body, then fully tighten using a torque driver set to 23 ± 2 cNm.

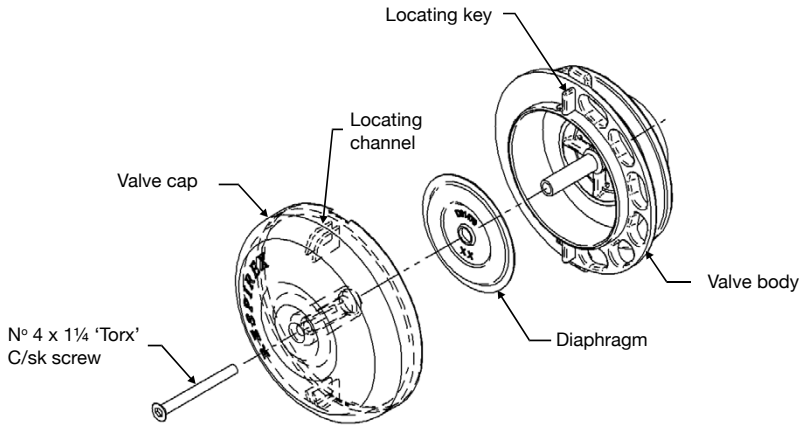

Fig. 23

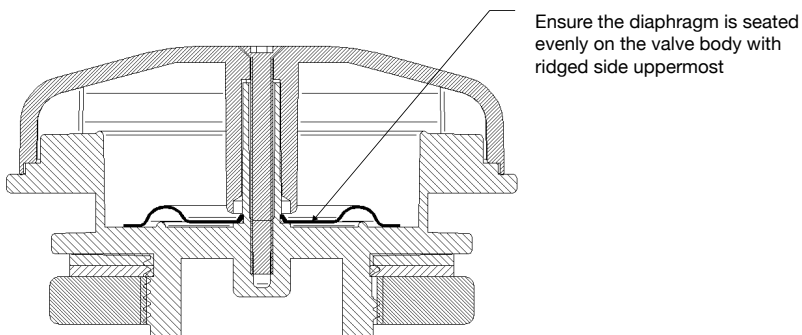

Fig. 24

Removing Exhalation Valve Assembly

1. Lay the suit on a clean flat surface and open the zip to its fullest extent.
2. Using a two pin wrench (Tool No. G01486) locate the pins into the two holes in the exhalation valve retaining ring and unscrew.
3. Remove the rubber sealing washer.
4. Then from the outside of the suit carefully remove the exhalation valve assembly.

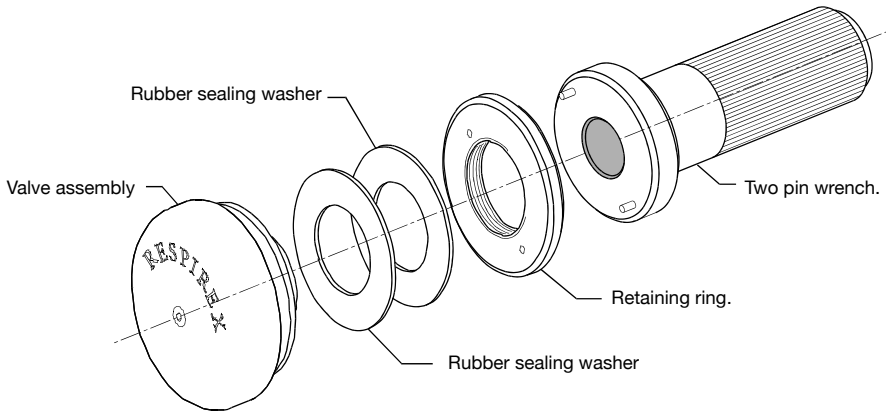

Fig. 25

Replacing Exhalation Valve Assembly

1. The new exhalation valve will have all the parts screwed together, so remove the retaining ring and one of the rubber sealing washers.
2. Check that the remaining rubber sealing washer is laying flat against the valve body.
3. Locate the thread on the exhalation valve assembly through the hole in the back of the suit.
4. Locate the second rubber sealing washer around the thread on the valve body so that it is laying flat against the material of the suit .
5. Hand tighten the retaining ring onto the exhalation valve.
6. Check that the exhalation valve is orientated correctly (the Respirex lettering should be at the top of the valve and the three slots under the cover must be at the bottom).
7. Tighten the retaining ring using the two pin wrench (Tool No. G01486).

Decontamination

The end user shall be the sole judge for how long a limited-use gas-tight suit manufactured from **Chemprotex™ X** can be worn on a specific application, and whether or not the garment can be sufficiently cleaned or decontaminated. Preliminary washing by means of a high pressure shower will remove most of the contaminate from the outer surfaces of the suit sufficient to allow the wearer to undress from the garment.

Should you not have access to a high pressure shower, the suit can be sprayed with copious quantities of water and a suitable detergent and neutralizer for a minimum period of 5 minutes.

If the garment has been used in acid the recommended neutralizer is a solution of bicarbonate of soda and water (6% bicarbonate of soda w/v). Water will neutralize alkali contamination.

If you intend to re-use the garment it should now be removed for further cleaning.

The inner surfaces should be sprayed with Synodor® to kill all bacteria within the garment.

The outer surfaces can be cleaned using a diluted solution of Citrikleen (20 parts water to 1 part Citrikleen) applied using a soft cloth or soft brush if necessary. Never use a washing machine, spin or tumble drier.

Remove all excess water and allow the suit to dry naturally.

Warnings



HAND WASH ONLY

DO NOT SPIN



DO NOT DRY CLEAN



DO NOT BLEACH



DO NOT IRON



DO NOT TUMBLE DRY

DO NOT USE CLEANING SOLVENT

DO NOT USE AGGRESSIVE CLEANING POWDERS

DO NOT SCRUB THE SURFACE OF THE FABRIC

Cleaning Accessories

The outer surfaces of the suit can be cleaned with Citrikleen, Part No. F00938.

The inner surfaces of the suit can be cleaned with Synodor® Odor San, Part No.F00936; this will neutralize any bacteria build-up within the suit.

The visor can be cleaned with Respirex 'Fog-Off', Part No. F00934.

The zip must be regularly lubricated with 'Max-Wax™', Part No. F00149.

All these accessories are available from Respirex. Please contact our Customer Services Department on Tel: +44(0) 1737 778600.

Storage

When not in use it is recommended that the suit is stored in the container supplied. An internal pressure test in accordance with EN464 : 1994 should be carried out after every use if it is deemed that the suit may be re-used. The suit must always be stored in a dry, decontaminated, clean condition with the zip fully waxed and closed leaving approximately 10cms (4") open.

Based on the results of accelerated ageing tests, the projected shelf life of **Chemprotex™ X** is five years, as long as the material is not stored in sunlight or in excessive heat (>40°C). Additional research on **Chemprotex™ X** material would suggest a possible shelf life of up to ten years.

In order to maintain the level of protection offered, care should be taken to minimize the risk of damage occurring to the suits during transportation between work areas. It is recommended that all suits are transported in a suitably sized rigid container resistant to penetration by sharp objects, abrasive surfaces, chemicals, oils, solvents etc.

NOTE: The zip should always be waxed when in the fully closed position. This is to prevent wax blocking the inner portion of the zip teeth leading to possible failure of the zip.

Conducting An Internal Pressure Test

Manual Test Box - Test Method

1. Lay the suit out as flat as possible, away from any source of heat and/or currents of air. Seal all but one of the exhalation valves with the rubber bungs provided (see Fig. 26 & 27). Visually inspect the suit and remove any creases and folds as far as is practicable. Leave the suit at ambient temperature ($20^{\circ}\text{C} \pm 5^{\circ}\text{C}$) for minimum of 1 hour.

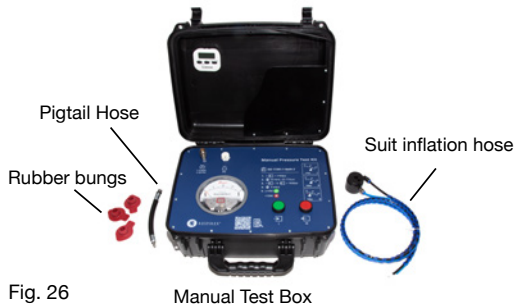

2. Connect the spiral wrapped suit inflation hose fitted with the exhalation valve test plug to the test box outlet coupling, marked with the suit icon
3. Connect a suitable compressed air source providing air at a minimum of 15 PSI (1.03 bar) and a maximum of 58 PSI (4 bar) to the inlet coupling marked with the compressor icon via the short black pigtail hose (this is fitted with the airline coupling specified when the box is ordered).
4. Using a 2mm hexagon key, loosen the screw from the centre of the exhalation valve that has not been sealed with a bung and remove the cap.
5. Carefully stretch the diaphragm over the centre spigot to remove from the exhalation valve body (Fig. 29).
6. Push the exhalation valve test plug into the exhalation valve body until sealed (Fig. 30)



Fig. 28



Fig. 29

7. Press and hold the **green** inflation button (marked **I**) to begin inflation. Ensure that any creased areas are unfolded and that the suit takes up its full shape (Fig.30). Regularly check the inflation level by releasing the green button and checking the gauge.



Fig. 30

8. When the pressure begins to approach 1750 Pa inflate a little at a time until the required 1750 Pa pressure is reached. Once a pressure of 1750 Pa is reached, release the green button.
9. As the material stretches the pressure will drop. For 10 minutes keep adding sufficient air to maintain the pressure at 1750 Pa.
10. After 10 minutes reduce the pressure in the suit by pressing and holding the **red** deflate button (marked **O**) until a pressure of 1650 Pa is reached. Allow a further 6 minutes to elapse (without adding any air) and record the pressure drop in pascals. The pressure drop must not be more than 300 Pa or 18% (e.g. the final pressure must be ≥ 1350 Pa) to comply with EN 943-1:2015.

After completing the test

1. Deflate the suit using the **red** deflate button (marked **O**), then open the zip slowly
2. Remove the exhalation valve test plug from the exhalation valve
3. Carefully stretch the diaphragm over the centre spigot making sure that it is correctly orientated and that the hole in the diaphragm is located under the shoulder of the spigot (see page 9).
4. Replace the exhalation valve cap making sure that the location channel on the cap is located over the location key on the exhalation valve body (the RESPIREX lettering should be at the top).
5. Remove the other exhalation valve bung(s)

Chemical Permeation Testing At Respirex

Respirex will test their own materials against any chemical that the customer requires. In this way, the customer can be advised and recommended the most suitable material to use against any challenging chemical encountered in the workplace.

Permeation is the process by which a chemical moves through protective clothing material on a molecular level. The permeation tests are carried out according to both the European standard EN ISO 6529:2001 and the American standard ASTM 739. The clothing material is exposed to the challenging chemical in a permeation cell so that breakthrough times and permeation rates can be measured. Breakthrough time is the time taken for the chemical to permeate through the material after continuous contact with the outer surface of a chemical safety suit. Permeation rates, measured in $\mu\text{g (min.cm}^2\text{)}$, are an indication of the amount of chemical reaching the person inside the suit after breakthrough occurs.

For advice on chemical permeation or decontamination contact Respirex on Tel : +44 (0)1737 778600, Fax : +44 (0) 1737 779441 or Email: info@respirex.co.uk, where our qualified staff will be happy to help you. Contact outside of normal working hours (9.00am-5.00pm) on Tel : +44 (0)1737 778600 answer phone, leave details of your enquiry and we will deal with your query with the minimum of delay.

Permeation Performance

The following test results indicate the resistance to permeation by chemicals of Chemprotex™ X material, gloves and visor as required EN943-2: 2019. Information on the permeation resistance of safety boots (if fitted) is detailed on a separate data sheet supplied with the suit.

All tests carried out under laboratory conditions by independent accredited laboratories in accordance with ISO 6529: 2013 unless otherwise stated.

Table shows average breakthrough times in minutes.

Chemical	Physical State	Chemprotex™ X Material	Kemblok™ Glove	Visor	Suit Seams
Acetone	L	>480 min	>480 min	>480 min	>480 min
Acetonitrile	L	>480 min	>480 min	>480 min	>480 min
Ammonia	G	>480 min	>480 min	>480 min	>480 min
Carbon Disulphide	L	>480 min	>480 min	>480 min	>480 min
Chlorine	G	>480 min	>480 min	>480 min	>480 min
Dichloromethane	L	>480 min	>480 min	>480 min	>480 min
Diethylamine	L	>480 min	>480 min	>480 min	>480 min
Ethyl Acetate	L	>480 min	>480 min	>480 min	>480 min
n-Hexane	L	>480 min	>480 min	>480 min	>480 min
Hydrogen Chloride	G	>480 min	>480 min	>480 min	>480 min
Methanol	L	>480 min	>480 min	>480 min	>480 min
Sodium Hydroxide 40%	L	>480 min	>480 min	>480 min	>480 min
Sulphuric Acid 98%	L	>480 min	>480 min	>480 min	>480 min
Tetrahydrofuran	L	>480 min	>480 min	>480 min	>480 min
Toluene	L	>480 min	>480 min	>480 min	>480 min

Key:

Physical State: L = Liquid , G = Gas

Sizing

The following table designates the range of height & chest sizes suitable for the GTR regular robustness gas-tight suit; check your body measurements to make sure you are suitable. Body measurements in cm (inch).

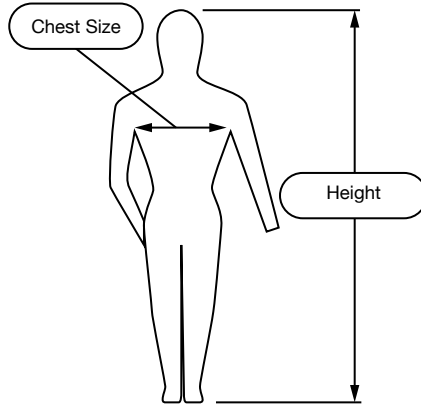





Suit Size	Height	Chest Size
Small (S)	163-175cm (5'4"-5'9")	88-96cm (35"-38")
Medium (M)	169-182cm (5'6½"-5'11½")	96-104cm (38"-41")
Large (L)	176-188cm (5'9"-6'2")	104-112cm (41"-44")
X-Large (XL)	182-194cm (5'11½"-6'4")	112-124cm (44"-49")
XX-Large (XXL)	188-200cm (6'2"-6'7")	124-136cm (49"-53½")

Product labelling

1. Manufacturer of garment and address:
Respirex International Ltd.
2. Manufacturer's Model number
3. Material of Manufacture.
4. Manufacturer's Order No.
5. Customer Name.
6. Date of manufacture: Day/Month/Year.
7. Garment Size

Size	Chest (cms)
S	88-96
M	96-104
L	104-112
XL	112-124
XXL	124-136

8. CE and UKCA mark including Notified Body and Approved Body code.
9. "Open Book Pictogram"; wearer must refer to the "Instructions for use" for further information.
10. Protection against liquid chemicals
11. Protection against electrostatic hazard
12. Protection against biological hazard
13. Five care pictograms indicating that clothing is not suitable for cleaning and reuse.

-  Pictogram 1 Hand wash
-  Pictogram 2 Do not bleach
-  Pictogram 3 Do not iron
-  Pictogram 4 Do not machine dry
-  Pictogram 5 Do not dry clean

RESPIREX INTERNATIONAL LTD,

Unit F Kingsfield Business Centre,
Philanthropic Road,
Redhill,
Surrey RH1 4DP
ENGLAND

Tel.: +44 (0)1737 778 600

Fax: +44 (0)1737 779 441

www.respirex.com

EU Module B and D
Type Examination By:

BSI,
Davy Avenue, Knowhill,
Milton Keynes, MK5 8PP,
ENGLAND

Notified Body No. 0086

BSI Group The Netherlands B.V.

Say Building, John M. Keynesplein 9,
1066 EP, Amsterdam,
NETHERLANDS

Notified Body No. 2797